

Gasket Strainers

Applications: These strainers are designed to protect downstream equipment from loose scale, weld slag, grit and other foreign material. They are ideal for insertion upstream of gas meters and regulators. Screens are stainless steel and available in 20, 40, 60, 80, 100 and 120 mesh.

Gasket Strainers are made of a steel mesh sandwiched between Garlock 3000 gasket material.

- Typically installed on the inlet of meter between flanges.
- Serve both as an inlet gasket and strainer
- Reduces installation size and cost.
- Available in Ring or Full face styles
- 2" – 8" sizes
- ANSI 150,300 or 600 ratings

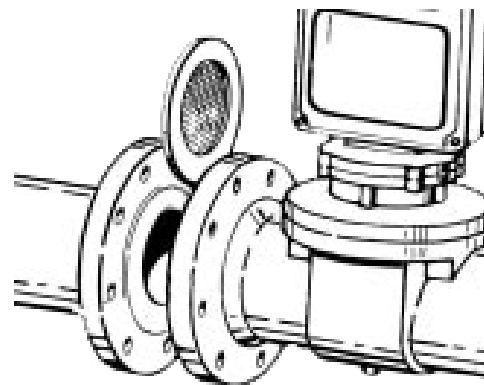
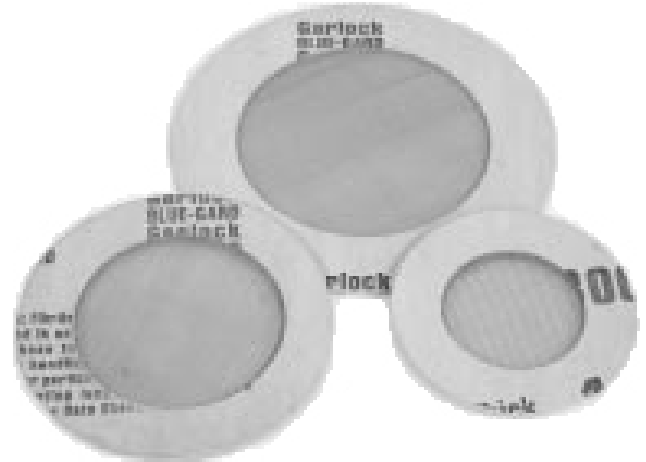

Typical Installation:

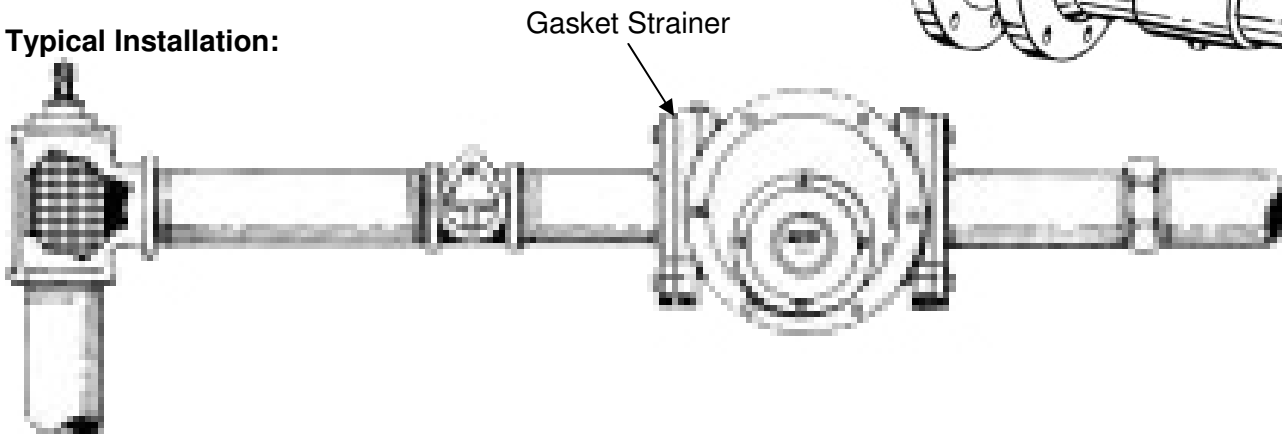

Last Line of Defense!

Protect your equipment with these inexpensive but highly effective strainers!

Distributed By:



Meter, Valve & Control
www.metervalveandcontrol.com
sales@metervalveandcontrol.com

Doc. Ref: F01A_Gasket_Strainer_FFC_v. 1

1499 Sunnybrook Road.
Alamo, CA 94507
Phone: (925) 519-4718
Fax: (925) 407-2903