

Pro-V™ Multivariable Flowmeter



VorTek Instruments' Pro-V multivariable flowmeters utilize three primary sensing elements—a vortex shedding velocity sensor, an RTD temperature sensor, and a solid-state pressure transducer—to measure the mass flow rate of gases, liquids and steam. Because the Pro-V is able to measure all process variables within a single device it provides exceptional accuracy, simplifies system design and reduces installation costs.

To enhance reliability, the Pro-V Model M23 insertion flowmeters feature a no-moving parts design and rugged, all-welded construction. They are easily installed with flanged or Male NPT process connections in any pipe size of two-inches and greater. Optional retractor or "hot-tap" hardware simplifies maintenance operations.

The Pro-V provides excellent rangeability and a low permanent pressure drop. To simplify installation and commissioning, all measured variables and programming menus are available on the instrument's easy to use display and control pad.

The product line is available with a wide range of options and meter configurations to meet your specific application requirements.

Model M23 Insertion Meter

- M23-V flowmeter provides cost-effective volumetric flow monitoring solution for most liquids
- M23-VT incorporates temperature sensing to provide a compensated mass flow reading of saturated steam
- M23-VTP multivariable meter delivers mass flow, temperature, pressure and density readings from a single installed device
- Insertion-style mounting permits installation in any pipe two inches and greater
- Easy to install and commission
- Field-configurable ranges, outputs and displays
- HART protocol communications
- Modbus communications available
- FM-approved and CENELEC/ATEX pending



VorTek
INSTRUMENTS

VorTek Instruments, LLC
8475 West I-25 Frontage Rd., Suite 300
Longmont, CO 80504 USA
Tel: 303/682-9999
Fax: 303/682-4386
info@vortekinst.com

Pro-V Model M23-VTP

The Model M23-VTP offers you flow computer functionality in a compact field device. This multivariable instrument incorporates temperature and pressure sensors to provide an instantaneous reading of compensated mass flow rate of gases, liquids and steam. In addition to outputs for totalized mass and alarm settings, the field-configurable electronics deliver up to three analog 4-20 mA outputs of five process measurements, including volumetric flow rate, mass flow rate, pressure, temperature and density.

Pro-V Model M23-VT

The Model M23-VT integrates a precision 1000 Ohm platinum RTD temperature sensor that can be used to calculate and output a compensated mass reading. This device is typically used to measure flow rates of saturated steam.

Pro-V Model M23-V

The Model M23-V delivers a direct reading of volumetric flow rate—generally the most cost-effective solution for liquid flow monitoring—in applications ranging from general water flows to hydrocarbon fuel flow measurement.

Pro-V Model M23-EM

The Model M23 Energy Monitoring option permits real-time calculation of energy consumption for a facility or process. The meter can be programmed to measure steam, hot water or chilled water. The Model M23-VTP flowmeter monitors one side of the process, either sent or return, and uses the input from a second separate temperature sensor on the opposite leg of the process to calculate the change in energy. Selectable energy units include Btu, joules, calories, Watt-hours, Megawatt-hours and Horsepower-hours. The local or remote electronics indicate two temperatures, delta T, mass total and energy total.

Performance Specifications

Accuracy

Mass flow rate accuracy for gas and steam based on 50-100% of pressure range.

Pro-V Model M23 Multivariable Flowmeter		
Process Variables	Liquids	Gas & Steam
Volumetric Flow Rate	± 1.2% of Rate	± 1.5% of Rate
Mass Flow Rate	± 1.5% of Rate	± 2.0% of Rate
Temperature	± 2°F (± 1°C)	± 2°F (± 1°C)
Pressure	± .3% of Full Scale	± .3% of Full Scale
Density	± .3% of Reading	± .5% of Reading

Repeatability

Mass Flow Rate.....	± .2% of rate
Volumetric Flow Rate	± .1% of rate
Temperature.....	± .2°F (± .1°C)
Pressure	± .05% of full scale
Density	± .1% of reading

Stability Over 12 Months

Mass Flow Rate.....	± .2% of rate
Volumetric Flow Rate.....	± negligible
Temperature.....	± .9°F (± .5°C)
Pressure.....	± .1% of full scale
Density.....	± .1% of reading

Response Time

Adjustable from 1 to 100 seconds

Operating Specifications

Process and Ambient Temperature

Process Standard Temperature (code ST): -40 to 500°F (-40 to 260°C)

Process High Temperature (code HT): to 750°F (400°C)

Ambient Operating: -5 to 140°F (-20 to 60°C)

Ambient Storage: -40 to 150°F (-40 to 65°C)

Pressure Transducer Ratings			
Full Scale Operating Pressure		Max. Over-Range Pressure	
psia	bara	psia	bara
30	2	60	4
100	7	200	14
300	20	600	40
500	35	1000	70
1500	100	2500	175

Pressure Ratings			
Style Connection	Process	Rating Code	Ordering
Compression Fitting	2-inch Male NPT	ANSI 600 lb.	CNPT
	2-inch 150 lb. flange	ANSI 150 lb.	C150
	2-inch 300 lb. flange	ANSI 300 lb.	C300
	2-inch 600 lb flange	ANSI 600 lb.	C600
Packing Gland	2-inch Male NPT	50 Psig (3.5 BarG)	PNPT
	2-inch 150 lb. flange	50 Psig (3.5 BarG)	P150
	2-inch 300 lb. flange	50 Psig (3.5 BarG)	P300
Packing Gland & Removable Retractor	2-inch Male NPT	ANSI 300 lb.	PNPT & RR
	2-inch 150 lb. flange	ANSI 150 lb.	P150 & RR
	2-inch 300 lb. flange	ANSI 300 lb.	P300 & RR
Packing Gland & Permanent Retractor	2-inch Male NPT	ANSI 600 lb.	PNPTR
	2-inch 150 lb. flange	ANSI 150 lb.	P150R
	2-inch 300 lb. flange	ANSI 300 lb.	P300R
	2-inch 600 lb. flange	ANSI 600 lb.	P600R

Power Requirements

Model M23-V: 12-36 VDC loop powered
 Model M23-VTP, DC option: 12-36 VDC, 100 mA max
 Model M23-VTP, AC option: 85-240 VAC, 50/60Hz, 2 Watts

Display

Alphanumeric 2 line x 16 character LCD digital display
 Six pushbuttons for full field configuration
 Pushbuttons can be operated with magnetic wand without removal of enclosure covers
 Display can be mounted in 90° intervals for better viewing

Output Signals

Analog: 4-20 mA, loop powered for volumetric meters
 Alarm: Solid state relay, 40 VDC
 Totalizer Pulse: 50 millisecond pulse, 40 VDC
 Volumetric: One analog, one totalizer pulse, HART
 Multivariable: Up to three analog signals, three alarms, one totalizer pulse, HART
 Multivariable option: Modbus process monitoring

Physical Specifications

Wetted Materials

316L stainless steel, plus:

- Dupont Teflon® based thread sealant on models with pressure transducer.
- Dupont Teflon® packing on standard temperature models with packing gland.
- Graphite based packing on high temperature models with packing gland.

FM Approvals

Explosionproof for Class I, Division 1, Groups B, C & D
 Dust-ignitionproof for Class II/III, Division 1, Groups E, F & G
 Nema Type 4x and IP66
 T6 at Tamb = 140°F (60°C)

Sizing Considerations

Piping Conditions		
Condition	Pipe Diameters, D	
	Upstream	Downstream
One 90° elbow before meter	10D	5D
Two 90° elbows before meter	15D	5D
Two 90° elbows before meter, out of plane	25D	5D
Reduction before meter	10D	5D
Expansion before meter	20D	5D
Partially open valve	25D	5D

Velocity Range

Maximum velocity, liquid: 30 feet/sec (9 meters/second)
 Minimum velocity, liquid: 1 foot/sec (.3 meters/second)
 Maximum velocity, gas or steam: 300 feet/sec (90 meters/second)
 Minimum velocity, gas or steam feet/sec (meters/second):

$$\frac{5}{\sqrt{\text{density (Lb/ft}^3)}} \quad \frac{6.1}{\sqrt{\text{density (kg/m}^3)}}$$

Consult the Vortek Instruments Sizing Program for easy calculation of flow range.

Water Minimum and Maximum Flow Rates						
Rate	Nominal Pipe Size (in)					
	3	6	8	12	16	24
GPM min	20.6	81.3	142	317	501	1138
GPM max	618	2437	4270	9501	15043	34144
Nominal Pipe Size (mm)						
	80	150	200	300	400	600
M ³ /hr min	5.2	20.4	35.4	79.2	125	284
M ³ /hr Max	157	614	1062	2337	3753	8537

Typical Saturated Steam Minimum and Maximum Flow Rates (lb/hr)						
Nominal Pipe Size (in)						
Pressure	3	6	8	12	16	24
5 psig	205	800	1385	3099	4893	11132
	2721	10633	18412	41196	65039	147954
100 psig	468	1831	3170	7092	11197	25472
	14246	55674	96407	215703	340546	774698
200 psig	632	2471	4278	9572	15111	34377
	25948	101405	175595	392880	620268	1411029
300 psig	762	2976	5153	11530	18203	41410
	37652	147145	254799	570093	900047	2047489
400 psig	873	3412	5908	13219	20870	47477
	49494	193420	334930	749382	1183103	2691404
500 psig	974	3805	6588	14741	23272	52942
	61543	240507	416468	931816	1471125	3346615

Typical Saturated Steam Minimum and Maximum Flow Rates (kg/hr)						
Nominal Pipe Size (mm)						
Pressure	80	150	200	300	400	600
0 barg	81	316	548	1226	1936	4404
	938	3667	6350	14209	22432	51039
5 barg	187	729	1263	2826	4461	10151
	4986	19486	33742	75495	119189	271187
10 barg	249	972	1683	3767	5947	13530
	8859	34620	59949	134132	211764	481821
15 barg	298	1164	2016	4510	7120	16200
	12700	49629	85939	192283	303570	690705
20 barg	340	1329	2301	5148	8128	18493
	16550	64676	111995	250581	395609	900119
30 barg	413	1612	2791	6246	9860	22435
	24357	95187	164827	368789	582234	1324739

Typical Air Minimum and Maximum Flow Rates (SCFM) Air at 70°F						
Nominal Pipe Size (in)						
Pressure	3	6	8	12	16	24
0 psig	56	220	381	852	1345	3059
	924	3611	6253	13991	22089	50250
100 psig	157	615	1065	2383	3763	8560
	7236	28279	48969	109564	172977	393500
200 psig	216	843	1460	3266	5156	11729
	13588	53101	91950	205732	324804	738886
300 psig	262	1022	1770	3960	6251	14221
	19974	78059	135169	302430	477467	1086176
400 psig	301	1175	2034	4551	7186	16346
	26391	103136	178593	399588	630859	1435121
500 psig	335	1310	2269	5077	8015	18233
	32834	128314	222191	497136	784865	1785464

Typical Air Minimum and Maximum Flow Rates (nm ³ /hr) Air at 20°C						
Nominal Pipe Size (mm)						
Pressure	80	150	200	300	400	600
0 barg	89	347	601	1345	2124	4833
	1463	5716	9897	22145	34962	79547
5 barg	217	847	1467	3282	5181	11788
	8702	34006	58885	131751	208004	473266
10 barg	294	1148	1987	4446	7020	15972
	15975	62430	108105	241878	381870	868857
15 barg	355	1385	2399	5368	8474	19282
	23280	90979	157542	352487	556497	1266182
20 barg	407	1589	2751	6156	9718	22112
	30615	119642	207175	463539	731823	1665095
30 barg	495	1934	3349	7493	11829	26915
	45361	177268	306961	686801	1084302	2467081

Turndown

Turndown is application dependent. Consult the Vortek Instruments Sizing Program for exact values. Turndown can exceed 100:1

Dimensional Outline: Compression Fitting Models

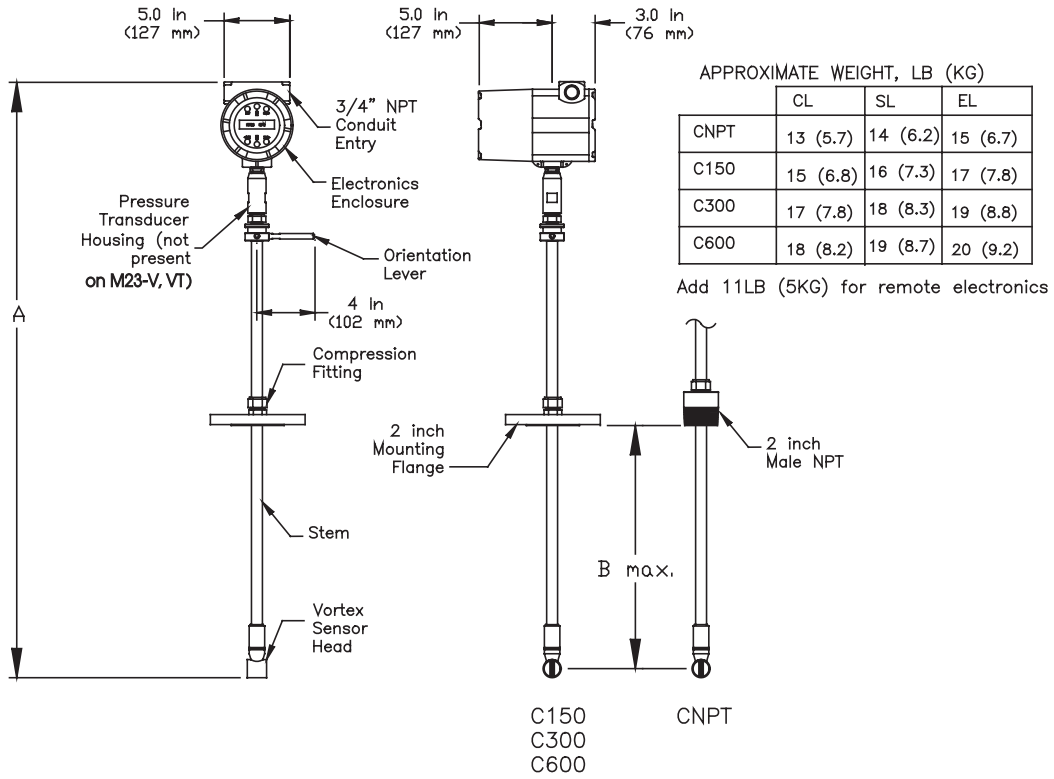

MODEL M23-V,VT in (mm)	CL/Compact Length		SL/Standard Length		EL/Extended Length	
	A	B	A	B	A	B
CNPT, Compression Fitting, Male NPT	21.6 (549)	9.8 (249)	38 (965)	26.2 (665)	50 (1270)	38.2 (970)
C150, Compression Fitting, 150 lb. Flange	21.6 (549)	10.9 (277)	38 (965)	27.3 (693)	50 (1270)	39.3 (998)
C300, Compression Fitting, 300 lb. Flange	21.6 (549)	10.8 (274)	38 (965)	27.2 (691)	50 (1270)	39.2 (996)
C600, Compression Fitting, 600 lb. Flange	21.6 (549)	10.4 (264)	38 (965)	26.8 (681)	50 (1270)	38.8 (986)

MODEL M23-VTP in (mm)	CL/Compact Length		SL/Standard Length		EL/Extended Length	
	A	B	A	B	A	B
CNPT, Compression Fitting, Male NPT	24.6 (625)	9.8 (249)	41 (1041)	26.2 (665)	53 (1346)	38.2 (970)
C150, Compression Fitting, 150 lb. Flange	24.6 (625)	10.9 (277)	41 (1041)	27.3 (693)	53 (1346)	39.3 (998)
C300, Compression Fitting, 300 lb. Flange	24.6 (625)	10.8 (274)	41 (1041)	27.2 (691)	53 (1346)	39.2 (996)
C600, Compression Fitting, 600 lb. Flange	24.6 (625)	10.4 (264)	41 (1041)	26.8 (681)	53 (1346)	38.8 (986)

Dimensional Outline: Packing Gland Models

REMOVABLE RETRACTOR CAN BE USED WITH THESE MODELS

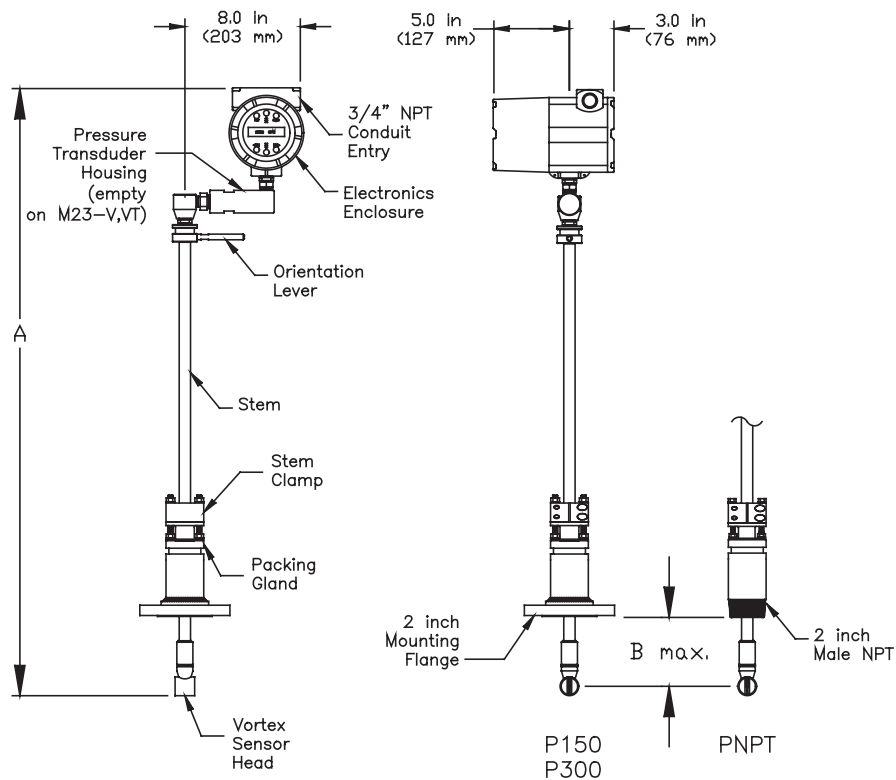

MODEL M23 in (mm)	SL/Standard Length		EL/Extended Length	
	A	B	A	B
PNPT, Packing Gland, Male NPT	40.5 (1029)	21.5 (546)	52.5 (1334)	33.5 (851)
P150, Packing Gland, 150 lb. Flange	40.5 (1029)	21.1 (536)	52.5 (1334)	33.1 (841)
P300, Packing Gland, 300 lb. Flange	40.5 (1029)	21.1 (536)	52.5 (1334)	33.1 (841)

APPROXIMATE WEIGHT, LB (KG)

	SL	EL
PNPT	16 (7.1)	17 (7.6)
P150	21 (9.4)	22 (9.9)
P300	25 (11.3)	26 (11.8)

Add 11 LB (5 KG) for remote electronics

Dimensional Outline: Packing Gland Models with Permanent Retractor

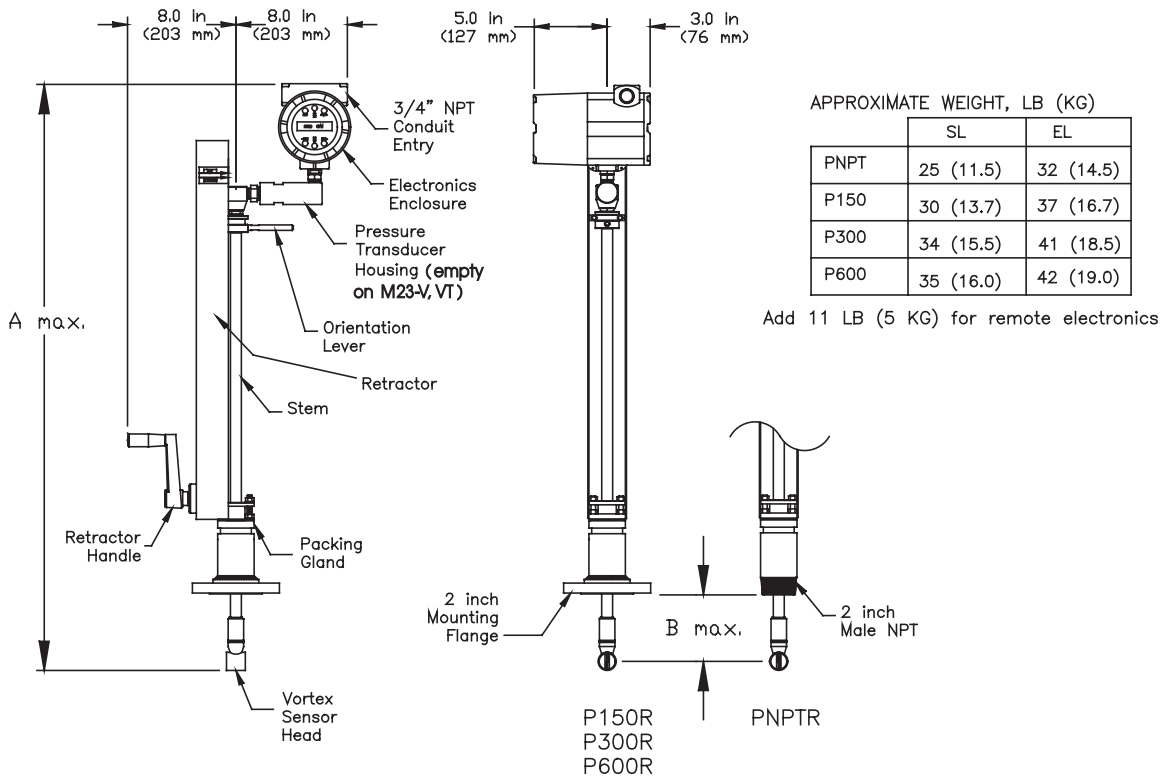

MODEL M23 in (mm) WITH PERMANENT RETRACTOR	SL/Standard Length		EL/Extended Length	
	A	B	A	B
PNPTR, Packing Gland, Male NPT	40.5 (1029)	21.5 (546)	52.5 (1334)	33.5 (851)
P150R, Packing Gland, 150 lb. Flange	40.5 (1029)	21.1 (536)	52.5 (1334)	33.5 (841)
P300R, Packing Gland, 300 lb. Flange	40.5 (1029)	21.1 (536)	52.5 (1334)	33.1 (841)
P600R, Packing Gland, 600 lb. Flange	40.5 (1029)	21.1 (536)	52.5 (1334)	33.1 (841)

Dimensional Outline: Remote Electronics Option

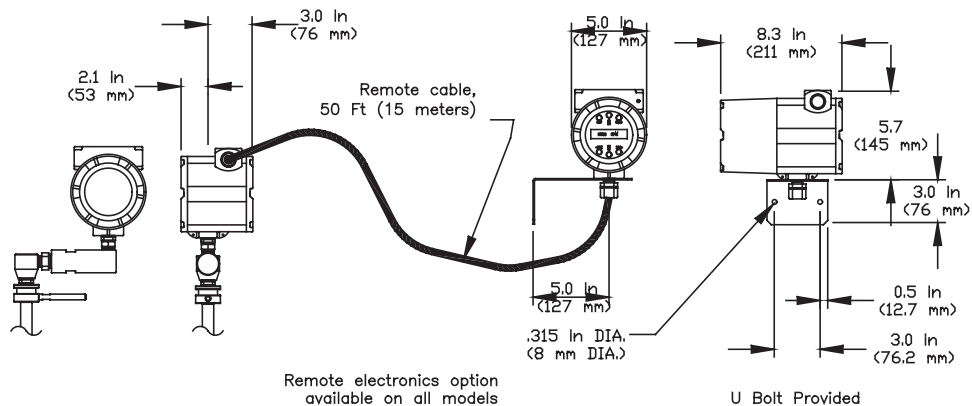

Ordering Information—Pro-V Model M23

